

USER GUIDE

ONE PIECE DUAL-FLUSH TOILET



TOOLS AND MATERIALS YOU MAY NEED



A. Water Supply Kit



B. Adjustable Wrench



C. Phillips Screwdriver



D. Level



E. Nut Driver or Socket Set



F. Putty Knife



G. Tape Measure

PACKAGE CONTENTS

One-Piece Toilet



Wax Ring/Gasket

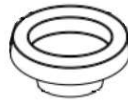

Floor Mounting Hardware

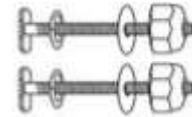

Mounting Hole Cover Kit

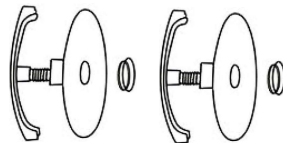

BEFORE INSTALLATION



Please make sure the following requirements are met.

1. Minimum distance between finished wall and center of the floor drain should be 12".
2. Minimum distance between the center of the shut-off valve to the center of the drain should be 7-1/2" (FIG 1).

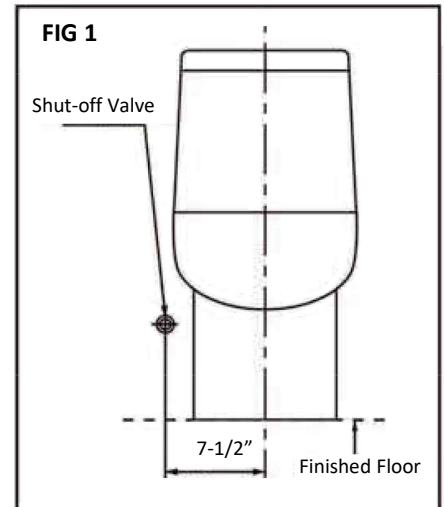

INSTALLATION

1. Install new floor bolts into floor flange. (FIG 2)

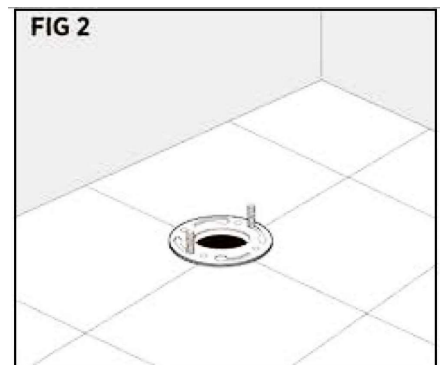

2. Attach flexible water supply line (not included) to the inlet of the fill valve and hand tighten ONLY. **At this point, DO NOT connect to the water shut-off valve. (FIG 3)**

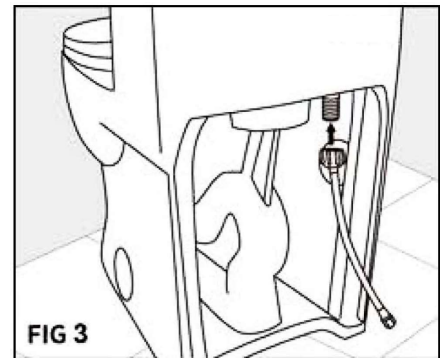

3. Place the new Wax Ring around the waste flange of toilet bowl. (FIG 4)

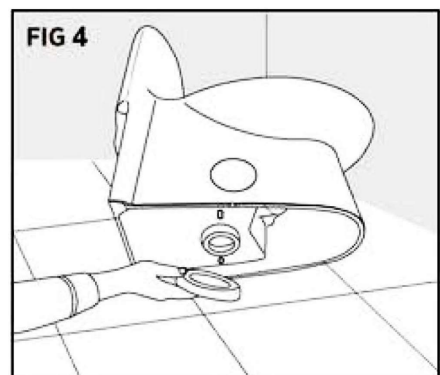

INSTALLATION (Continue)

4. Lower the toilet onto the closet bolts, so the bolts project through mounting holes in base of toilet. (FIG 5) Using a rocking motion, press the bowl down to position the toilet onto the flange



5. Install plastic cap washers, followed by metal washers and nuts onto the closet bolts. (FIG 6) Tighten the bolts alternately until toilet is firmly seated on the floor. **CAUTION: DO NOT OVERTIGHTEN NUTS, SEVERE DAMAGE MAY OCCUR**

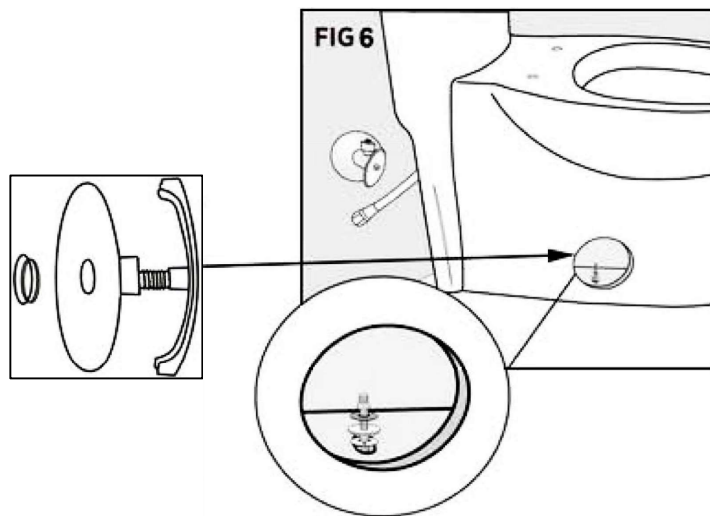

6. Install plastic cap cover (FIG 6)

7. Connect the flexible water supply line (not included) to the shut-off valve. Tighten coupling nut securely. (FIG 7)

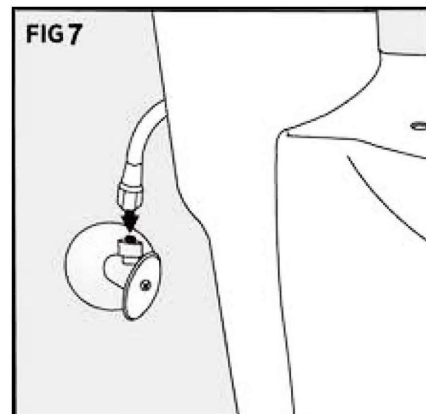

8. Turn on water supply valve and allow tank to fill until float valve rises to shutoff position. Check for leakage at fittings, tighten or correct as needed.

WARRANTY

1-Year Limited Warranty

Our products have been manufactured under the highest standards of quality and workmanship. innoci usa warrants to the original purchaser that our products are free from any defects in material and workmanship by normal use for 1 year from the date of purchase. A replacement for any defective part will be supplied FREE OF CHARGE for installation by you.

This warranty is valid to the original purchaser only and does not cover product damage due to installation error, product abuse, product misuse, etc. whether or not performed by professionals. innoci usa will not be responsible for labor charges and/or damage incurred in installation, repair or replacement nor for any incidental or consequential damages.

All warranty claims should be sent to customerservice@innoci-usa.com or call 1.866.479.8076. Our customer service representative will contact you promptly to help you go through the process until you are completely satisfied with our products.

SHORTAGE OR DAMAGED PRODUCTS All shipments are carefully inspected and counted before leaving our distribution centers. Please inspect carefully on receipt of merchandise, noting any discrepancy or damage on the carrier's freight bill at that time, and file a claim with the carrier within 10 days from receipt of order. Then contact our office. Deductions from invoices for shortages or damage claims will not be allowed.

RETURN NEW GOODS All claims for returns or adjustments must have prior approval and return authorization (RA) number. Only original, sealed product in salable condition are eligible for return. Credit for authorized returns will be issued at the net price paid for the product and subject to a 15% restocking/handling fee. Merchandise is to be returned via prepaid freight. All unauthorized returns will be refused or subject to a 25% restocking/handling fee.

To request an "RA" number: Contact our Customer Service Representatives at customerservice@innoci-usa.com. We will send you a Return Authorization Number (RA) by return email. Please take necessary precautions when returning merchandise to prevent additional damage. Insurance is the responsibility of the shipper.

1. There is not enough flushing power

- a. Try to lengthen the actuator rods located under the tank lid. A small amount at a time. If water start leaking from tank to bowl, the actuator rods are adjusted too long.
- b. Try to adjust the fill valve to a higher level. (Refer to fill valve manual)
- c. Try to adjust the flush valve to a higher level. (Refer to flush valve manual)

2. Water keep leaking from tank to bowl

- a. Try removing the tank lid. If the leaking stop, try to shorten the actuator rods located under the tank lid.
- b. Try to clean the seat and seal under the flush valve. Turn the flush valve approx. 45 degrees clock-wise to lift the flush valve body up. Clean the seat and seal and put it back.

innoci usa, Inc.

14530 Best Ave,
Santa Fe Springs, CA 90670

www.innoci-usa.com